

Toolless Power Strip Mount

Developed by Luke Payant

Access Onshape Document: deskmount.lukepayant.com

Design Overview

A mount designed to attach a power strip to the side of a desk, improving workspace organization and increasing usable desk area. Notable design considerations include:

1. A hook-based attachment to the desk cross-member to avoid damaging desk surfaces.
2. Simple, tool-free assembly and disassembly.
3. A sliding mounting plate that allows the power strip to be easily repositioned or removed.
4. A four-component design to promote structural rigidity and manufacturability.

Figure 1 contains screenshots of the CAD model that was developed in Onshape to fit the specific geometry of the desk [1]. The design consists of a U-bracket and mounting plate that were each fabricated in *Rapid PLA Plus (Black)* using a Neptune 3 PLUS FDM 3D printer [2-3] after which they were installed on the desk (see Fig. 2).

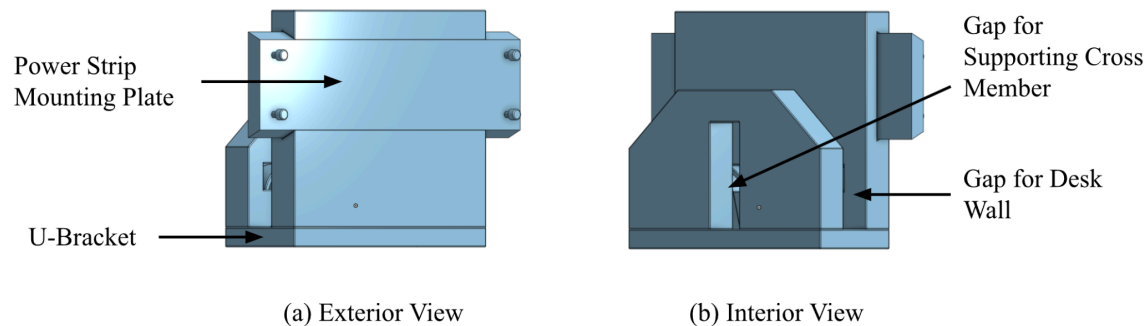

Fig. 1. Annotated screenshots showing the final CAD model developed in Onshape from two perspectives. (a) View of the side visible from the exterior of the desk. (b) View of the side visible while looking underneath the desk, at the interior face of the desk wall.

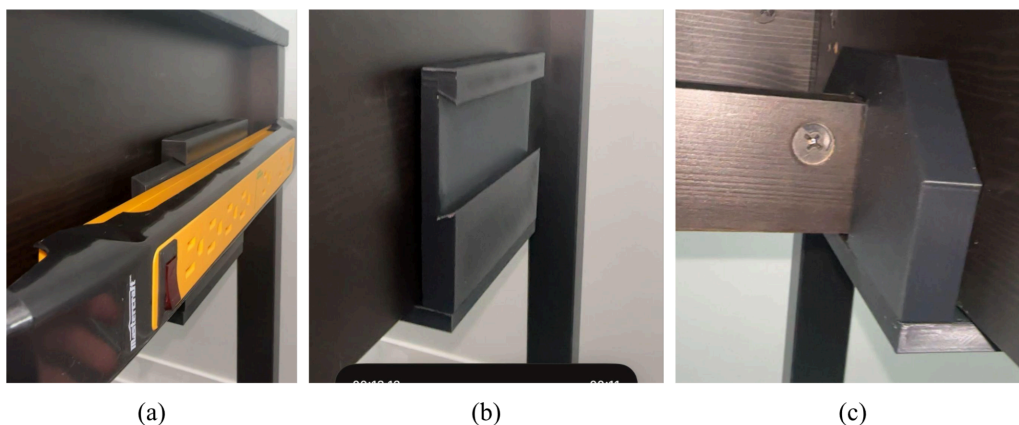

Fig. 2. The final product, fabricated in black PLA using FDM 3D printing, is shown mounted on the desk from three different views. (a) Exterior face of the desk wall with power strip and mounting plate attached. (b) Exterior face of the desk wall with power strip and mounting plate removed. (c) Interior face of the wall, viewed from underneath the desk, showing the design connected to the desk's cross-member.

Table of Contents

I. Project Context.....	3
A. Motivation.....	3
B. Design Requirements.....	3
C. Existing Desk Features.....	3
II. Design Details.....	4
A. U-Bracket Joints.....	4
B. Components.....	5
III. Design Methods.....	7
A. Tools and Software.....	7
B. Design-for-Manufacturability Considerations.....	7
C. Prototyping & Testing.....	9
IV. Manufacturing.....	10
A. Method.....	10
B. Results and Discussion.....	10
V. Evaluation.....	11
A. Short-Term Performance.....	11
B. Long-Term Performance.....	11
C. Areas for Improvement.....	12
References.....	13

I. Project Context

This section outlines the background relevant to the design process including the need motivating the design, key constraints, and the structural elements of the desk that are utilized by the final product.

A. Motivation

A power strip is used to provide power and surge protection to devices at this personal desk. If kept on the ground, the power strip is less accessible and the space becomes untidy. If kept on top of the desk, the power strip reduces the already limited available desk-space. Thus, there is a need to mount the power strip somewhere else. The mount was specifically designed for the HEMNES desk from IKEA [1].

B. Design Requirements

The following key requirements must be satisfied:

1. The design shall not cause permanent modification or damage to the desk, power strip, or any supporting structure (e.g. designs fixed to the wall and/or desk using mounting screws are not viable solutions).
2. The power strip shall be accessible while sitting at the desk to facilitate the removal and insertion of power connectors.
3. The design shall not fail under loads expected from normal use, such as the weight of power strip and the forces applied to remove/insert power connectors.

C. Existing Desk Features

Sketches of the desk shown in Fig. 3 highlight two key structural members. In subsequent sections, these members will be referred to as the cross-member (orange) and the desk wall (green).

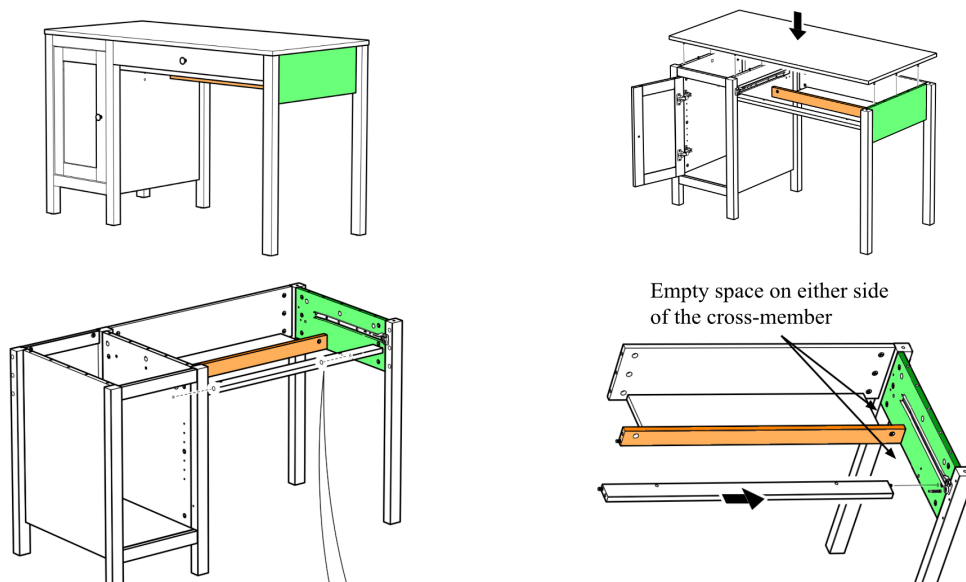

Fig. 3. Four sketches taken from the instruction manual of the desk [1] that are edited to identify the cross-member (orange) and the desk wall (green). The space on either side of the cross-member, which is most visible in the bottom-left sketch, is essential for the installation of the desk mount.

II. Design Details

This section outlines the methods used to join components together followed by a description of each component that highlights features that contribute to the final design. In the following sections, views are defined as shown in Fig. 4.

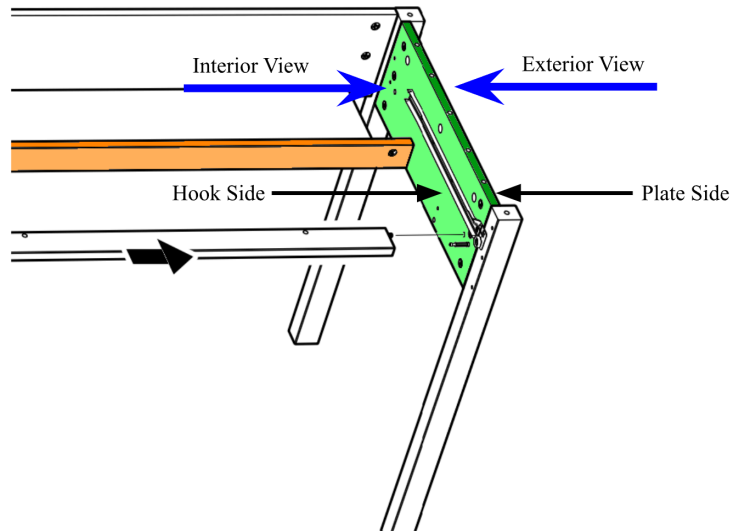

Fig. 4. Annotated version of Fig. 3 defining the interior and exterior views and labeling the hook side and plate side of the desk wall.

A. U-Bracket Joints

The U-bracket is composed of three components joined together. Figure 8 shows the semi-permanent method of connection that was implemented to withstand the forces transferred through the joints while still allowing toolless assembly and disassembly. The connection consists of complementary mating features referred to hereafter as the pocket and the retainer (see Fig. 8).

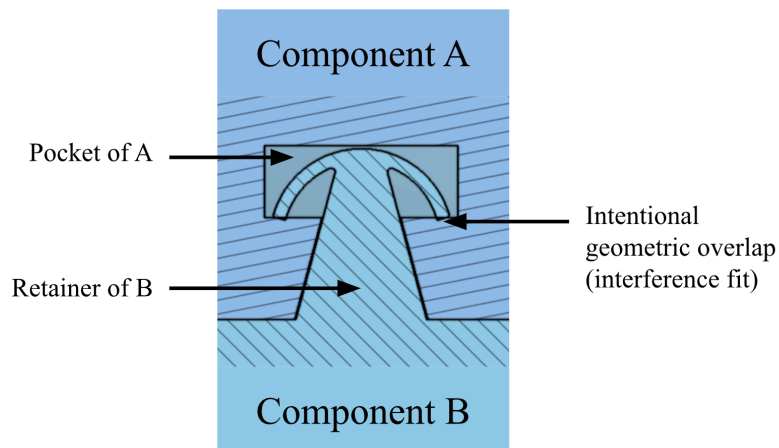

Fig. 5. A representation of the connection design used to join U-bracket components. The pocket and retainer features are defined in this figure to reference in subsequent sections.

As shown in Fig. 5, there is an intentional overlap between the retainer and pocket geometries in the CAD model. This interference forces the thin ‘arms’ of the retainer to flex once inserted which compresses the parts together. This improves structural rigidity and load transfer throughout the mount.

B. Components

The design is composed of four components. Three components join together to form the U-bracket, while the fourth component is a mounting plate that interfaces directly with the power strip.

1) *U-Bracket Component 1 – Plate Side:* This component is visible from the exterior view and is designed to hold the Mounting Plate in place (see Fig. 6).

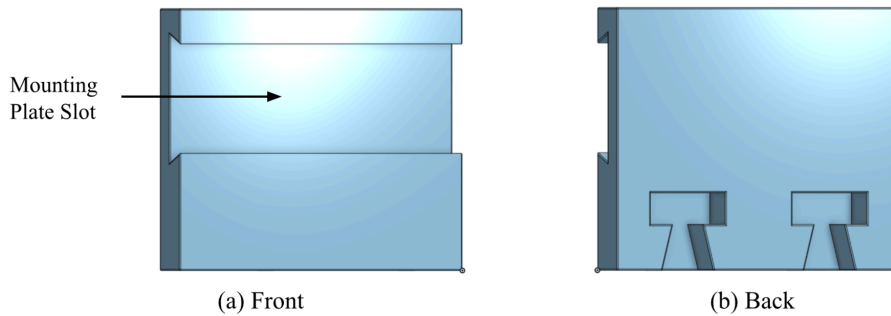

Fig. 6. The first of three components that form the U-bracket, shown from two opposing perspectives. (a) The front-side of the component faces away from the desk wall and features a slot with chamfered top and bottom edges to insert the Mounting Plate. (b) The back-side of the component rests against the plate side of the desk wall and features two pockets to permit the connection to U-Bracket Component 3.

2) *U-Bracket Component 2 – Hook Side:* This component, shown in Fig. 7, is visible from the interior view. The rectangular gap at the center of this component is dimensioned to fit the cross-member. When mated with U-Bracket Component 3, the cross-member becomes enclosed on all sides, thereby fully restricting movement of the mount.

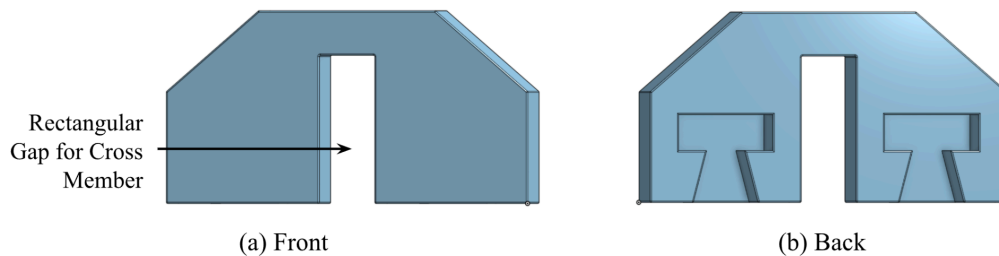

Fig. 7. The second of three components that comprise the U-bracket, shown from two opposing perspectives. (a) The front-side of the component faces away from the desk wall. (b) The back-side of the component rests against the hook side of the desk wall and features two pockets to permit the connection to U-Bracket Component 3.

3) *U-Bracket Component 3 – Base*: This component wraps around the underside of the desk wall and features four retainers to connect to the first and second components of the U-bracket (see Fig. 8).

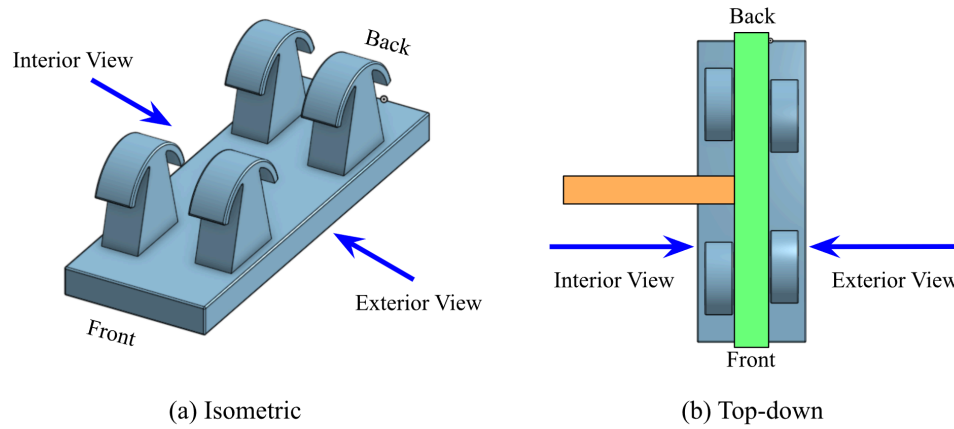

Fig. 8. The third of three components that comprise the U-bracket, shown from two perspectives. (a) Isometric view of the component highlighting the four retainers that correspond to the pockets featured in the other two U-bracket components. (b) A top-down view of the component, demonstrating the placement of the cross-member (orange) and the desk wall (green) between the four retainers.

4) *Mounting Plate*: As shown in Fig. 9(a), this component features four pins extending from its surface that interface with the four holes already present on the back of the power strip. Figure 9(b) shows the plate inserted into U-Bracket Component 1, fixing the powerstrip to the side of the desk. Due to the trapezoidal cross-section, the plate is constrained in two axes to resist external forces on the mount. The unloaded direction is left unconstrained, allowing for easy repositioning or removal of the power strip and Mounting Plate.

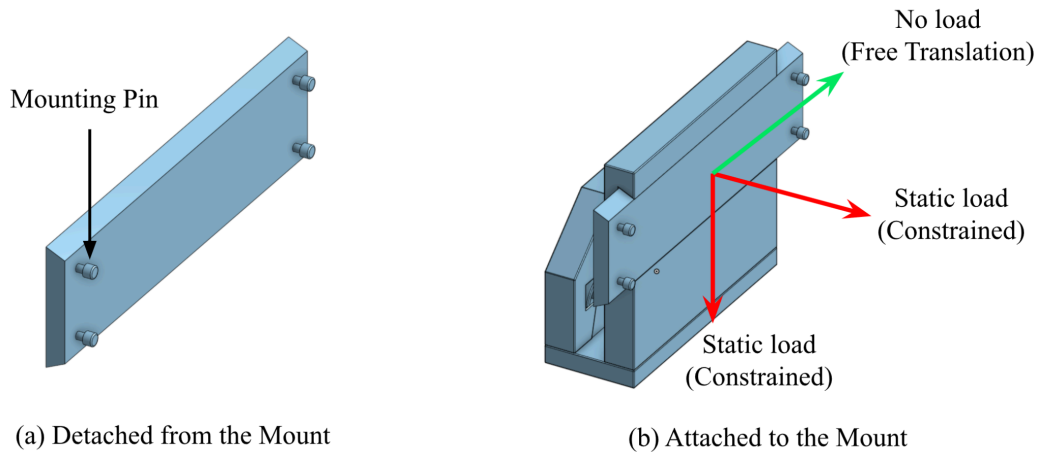

Fig. 9. The Mounting Plate for the power strip, shown in two isometric views: (a) detached from the mount; (b) connected to the mount to show the translational degrees of freedom.

III. Design Methods

The purpose of this section is to summarize key methods and considerations used during the design process. This includes design tools, design-for-manufacturability considerations, and the usage of prototyping to test important features.

A. Tools and Software

Onshape was used to design all four components described in Section II-B. The CAD model for each component was developed in a separate Part Studio tab before assembling the full model in a single Assembly tab. A link to the Onshape Document can be found in the header of Page 1.

6” calipers were used to measure dimensions of physical objects that interface with the mount including the cross-member, the desk wall and the power strip. Additionally, these calipers were used to visualize and estimate appropriate values for the unconstrained dimensions of the design, such as its thickness or height.

B. Design-for-Manufacturability Considerations

The manufacturing of a physical item, and the challenges that may arise during or after this process, must be considered throughout the design phase. This ensures that the designer does not violate manufacturing constraints and accounts for unavoidable manufacturing defects and process variability.

1) *Minimize Part Number:* This not only reduces potential weak points in the structure, but also simplifies assembly. For example, the mount was designed to not require additional connecting components, such as individual fasteners, which made the assembly process effortless. This also reduces the print-bed space required, which can significantly improve manufacturing efficiency at larger scales.

2) *Print Orientation:* The orientation of each component was considered from the beginning of the design phase to maximize tensile strength. Adhesion between 3D-printed layers of filament is weaker than the filament itself, so the strength of 3D-printed components vary with the direction of applied load.

When loaded, a structural member develops internal forces that are distributed over the cross-section. This makes print orientation especially significant for members subjected to axial tension, as illustrated in Fig. 10. When internal forces are perpendicular to the layer lines, interlayer cross-sections become points of failure. Conversely, when internal forces are parallel to the layer lines, the cross-section is continuously supported along the length of the member by uninterrupted extrusions of filament.

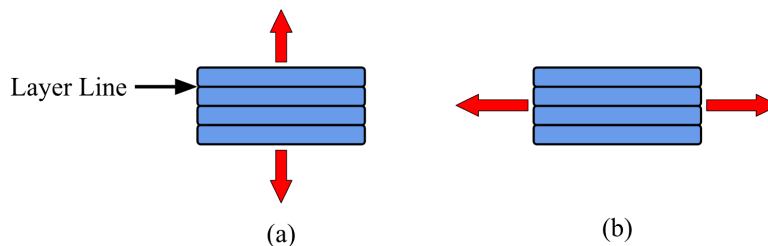

Fig. 10. A sketch to help visualize the impact of print orientation on the tensile strength of 3D-printed components. This figure shows four 3D-printed layers (blue rectangles) subjected to an applied tensile force (red arrows). (a) Force applied perpendicular to the layer lines results in lower tensile strength; (b) Force applied parallel to the layer lines results in higher tensile strength.

Since the mount is loaded eccentrically, the direction of internal forces varies within the structure. The geometry should therefore be divided into components based on regions with similar loading directions, so that print orientation can be optimized throughout the mount. The final configuration, consisting of four components, was selected because it balances manufacturing simplicity with control over print orientation.

a) U-Bracket Component 1: Axial forces are expected to be primarily compressive under the weight of the Mounting Plate and power strip. Layer line direction has minimal impact on compressive strength, so there is greater flexibility in the choice of print orientation for this component. As shown in Fig. 11(a), it was selected to print this component on its side to achieve a smooth surface for the Mounting Plate to be inserted.

b) U-Bracket Component 2: Axial forces are expected to be primarily tensile as this component supports the full weight of the mount. For this reason, this component was printed on its side to produce layer lines that are parallel to this vertical, tensile force (see Fig. 11(b)).

c) Mounting Plate: Both the weight of the power strip and the forces applied to remove cables generate axial tension within the Mounting Plate. Due to their small cross-sectional area, these forces produce especially high stresses within the mounting pins, and thus selecting an optimal print orientation for this component is critical. To resist the combined horizontal and vertical loading, the component was printed at an angle of 45° relative to the build plate, as shown in Fig. 11(c).

d) U-Bracket Component 3: The thin cross-sectional areas within the retainer design present similar concerns to those discussed for the mounting pins. As a result, this component was also printed at a 45° angle to resist both horizontal and vertical loading (see Fig. 11(d)).

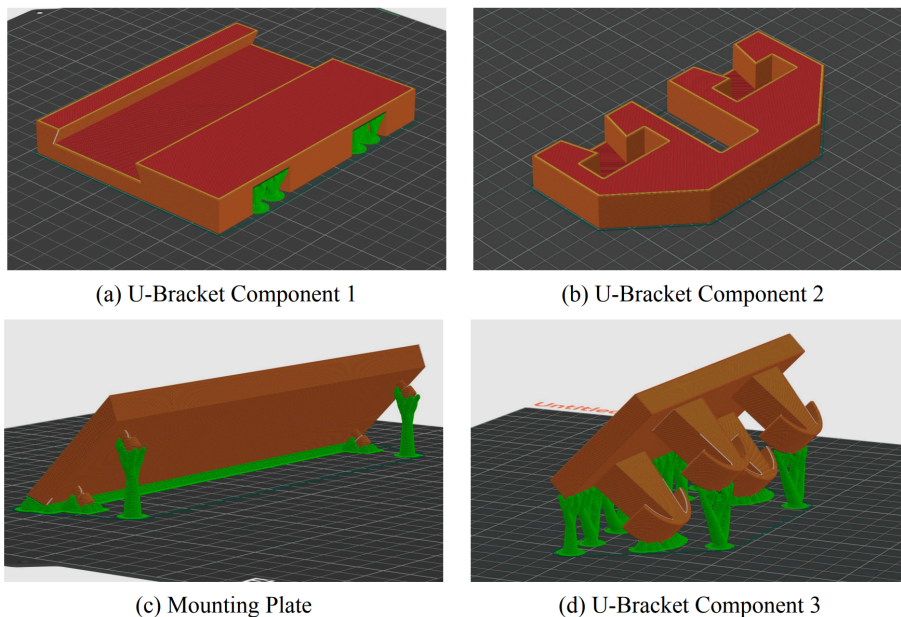

Fig. 11. Each component was printed at an orientation that would best support the expected loading conditions. (a) U-Bracket Component 1 and (b) U-Bracket Component 2 were printed on their sides. (c) the Mounting Plate and (d) U-Bracket Component 3 were each printed at a 45° angle relative to the build plate.

C. Prototyping & Testing

Certain features of this design require careful tolerancing to ensure they function as expected. To address this, features were prototyped to verify their real-world dimensions before the final components were fabricated. This helps mitigate dimensional inconsistencies that may be produced by factors including thermal contraction after printing.

1) *Mounting Pins:* To interface with the power strip, the shape and position of each pin on the Mounting Plate needs to be precise. Since thermal contraction becomes more noticeable as length increases, the largest spacing between pins is the most susceptible to this effect. First, a strip of the material was printed at three different lengths to help determine an appropriate value for this dimension (see Fig. 12(a)). Using this result, the slice of the Mounting Plate shown in Fig. 12(b) was printed to verify the pin geometry and the remaining pin spacings. The results of these tests were used to determine the final dimensions of the Mounting Plate.

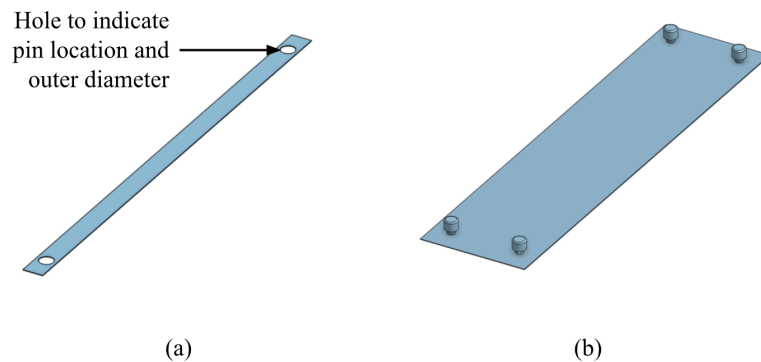

Fig. 12. Two tests used to verify key dimensions of the Mounting Plate. (a) A strip of the material was used to test the spacing required between mounting pins to interface with the power strip. (b) A slice of the Mounting Plate was printed to verify the pin geometry and the remaining pin spacings.

2) *Connections:* The connections forming the U-bracket were prototyped to test the interference fit. If the overlap between the retainer and pocket geometries is too large, the retainers may not be able to fit into the pockets without fracturing or plastically deforming. Conversely, if the overlap is too small, minimal force is required to separate the connections which results in an unstable structure. Figure 13 shows the prototype of this connection where it was used to join two small blocks together. This prototype was used to perform qualitative assessments of the connection's strength and rigidity as this level of assessment was sufficient for the scope of this project.

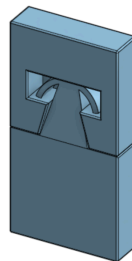

Fig. 13. Two blocks joined together by the retainer-pocket connection. This prototype was used to qualitatively determine an appropriate overlap between the retainer and pocket geometries.

IV. Manufacturing

This section discusses how the 3D printer and software were used to manufacture the components. This is followed by the challenges encountered during this process and the troubleshooting measures implemented to produce the final product.

A. Method

The final CAD models were sliced in OrcaSlicer [4] to generate G-code instructions for the Neptune 3 PLUS 3D printer. Despite the large build plate, a separate G-code file was generated for each component. Printing components individually avoids the risk of a failed print affecting the entire project, making this especially good practice when printing a design for the first time.

B. Results and Discussion

The first attempt, shown in Fig. 14, revealed a ripple-like pattern of layer separation. This could result from several factors, including low temperatures, excessive cooling, and high printing speeds. The calibration tools integrated in the OrcaSlicer software were used to observe the effects of varying each parameter independently.

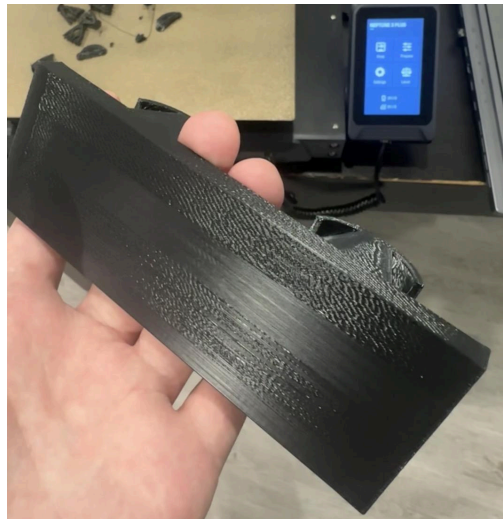

Fig. 14. The first attempt to print U-Bracket Component 3, showing significant layer separation and a ripple pattern in the extrusion.

The calibration tools showed that varying any one of these parameters had little to no effect on the issue. After further testing with a larger range of values, along with observing the printing process directly, it was hypothesized that the printer may have been under-extruding. Analyzing the relevant slicer settings revealed a simple error: an incorrect nozzle profile for the printer had been selected (nozzle diameter of 0.2 mm instead of 0.4 mm). This discrepancy caused the slicer to miscalculate the flow rate of filament, and correcting this mistake resolved the issue.

With the corrected slicer settings applied, all components were printed successfully. As a result of the prior prototyping, the components were assembled without issue and the mount was seamlessly integrated with the desk and power strip.

V. Evaluation

In this section, both the short- and long-term performance of the mount will be assessed. This informs potential improvements that would address performance concerns and broaden the possible applications of the design.

A. Short-Term Performance

After installation, the power strip felt secure and was easily accessible to insert and remove power cords while seated at the desk. The mount itself was rigid and did not show any signs of failure during use. Once removed, no permanent marks were left on the desk wall. Therefore, the desk mount satisfies the three key constraints outlined in Section I-B.

However, when loaded, clearance between the mount and the desk wall introduced greater deflection than expected, communicated further through Fig. 15. While this did not significantly impact the functionality of the mount, the bending introduces flexural stress concentrations within the U-bracket that may cause material creep over time.

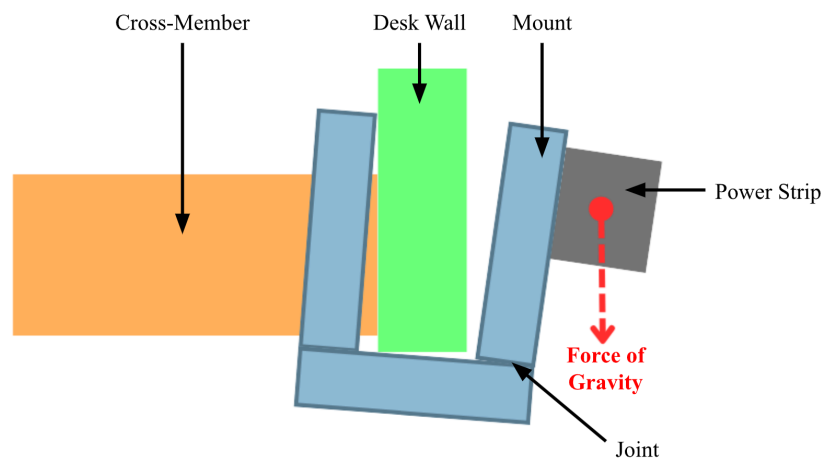

Fig. 15. A sketch providing an exaggerated representation of the mount's deflection from the desk wall. The mount rotates because the gravitational force acts at an offset from the pivot point. Due to the clearance between the mount and the desk wall, the mount rotates further than expected. This increases flexural stress at the joint labeled in this figure, promoting material creep over time and worsening the deflection.

B. Long-Term Performance

After approximately one year of use, removing and inserting power cords nearly every day, the desk mount continues to satisfy the constraints described in Section I-B. Figure 15 shows however, that deflection from the desk wall has increased, confirming the previous prediction. While the mount remains functional, this deflection has made the system feel less rigid, and the powerstrip less secure.

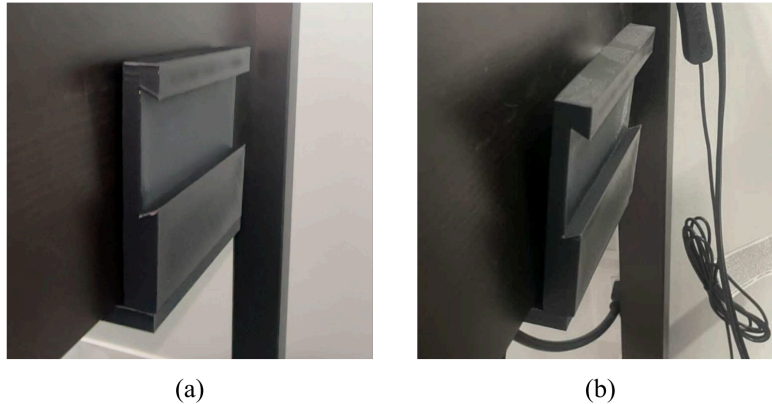

Fig. 16. (a) An image taken immediately after installation, and (b) an image taken after approximately one year of daily use to demonstrate the increase in deflection from the desk wall.

C. Areas for Improvement

Should this design be iterated further, reducing the mount's susceptibility to material creep would be an important area to explore first. Potential approaches include reducing the clearance between the mount and the desk wall and/or implementing additional connections between the mount and the desk.

Further improvements are only necessary to extend the design beyond the original scope of the project. First, if the design were to be produced at scale, material cost should be minimized by optimizing component geometries. Furthermore, the mount could be used as a design platform for attaching other items to a user's desk. Mounting plate designs could be developed for specific items such that they interface with the slot in U-Bracket Component 1. Since many items traditionally use mounting screws, the existing design of the Mounting Plate could also be iterated to accommodate multiple items by implementing a system that allows mounting pins to be repositioned on the plate. Similarly, modifications to the U-bracket could be explored to produce an adjustable design that integrates with other desk models. However, applications remain limited to desks with a cross-member-like feature unless a different mounting approach is pursued.

References

- [1] IKEA. “HEMNES Desk, black-brown.” *IKEA Canada*, Article No. 403.397.92. [Online]. Available: <https://www.ikea.com/ca/en/p/hemnes-desk-black-brown-40339792/>. Accessed: May 10, 2026.
- [2] ELEGOO. “Neptune 3 Plus FDM 3D Printer with Larger Build Volume of 320×320×400mm.” *ELEGOO US Official Store*. [Online]. Available: <https://us.elegoo.com/products/elegoo-neptune-3-plus-fdm-3d-printer-with-larger-build-volume-of-320x320x400mm>. Accessed: May 10, 2026.
- [3] ELEGOO. “Rapid PLA Plus Filament 1.75mm Colored 1kg.” *ELEGOO US Official Store*. [Online]. Available: <https://us.elegoo.com/products/elegoo-rapid-pla-plus-filament-1-75mm-colored-1kg>. Accessed: May 10, 2026.
- [4] OrcaSlicer Developers. “OrcaSlicer.” GitHub Repository. [Online]. Available: <https://github.com/OrcaSlicer/OrcaSlicer>. Accessed: May 10, 2026.